

REFERENCE	BT_2010_FR20_12_UK
DATE	1st June 2010
SUBJECT	Several updates and technical notes
PART	catalytic converter, MC reservoirs, ft airbox bracket, extinguisher loom, additional timing screen, primary shaft, roll hoop cover, differential

1. New supplier of catalytic converts:

A new catalytic convert from another supplier is now available from your Renault Sport spare parts department, under the ref. 07 11 166 121.



Both types of catalytic converters are allowed. There is no performance difference between the 2 models.

2. Master cylinder reservoirs

We found some reservoirs' caps without any hole. For safety reasons, these caps are not conform and must be replaced. You must contact your Renault Sport spare parts department to proceed to the exchange.



3. Front airbox bracket

A new airbox bracket in aluminium will be dispatched on all the cars for your next race, for free:



This bracket is now mandatory and the only one allowed. The old ones are no longer available.

4. Extinguisher connector

Renault Sport strongly recommends you to glue the small screw (1) of the extinguisher loom connectors (using low threadlocking glue), in order not to lose the small clip (2).



5. Additional timing screen

An additional timing screen (ref. 77 11 166 440) will be dispatched on all the cars for your next race, for free. This part will completely close the timing belt compartment.

This small screen (1) is tightened on the stud of the exhaust manifold which is the most at the front of the cylinder Head (timing belt side), as shown below:

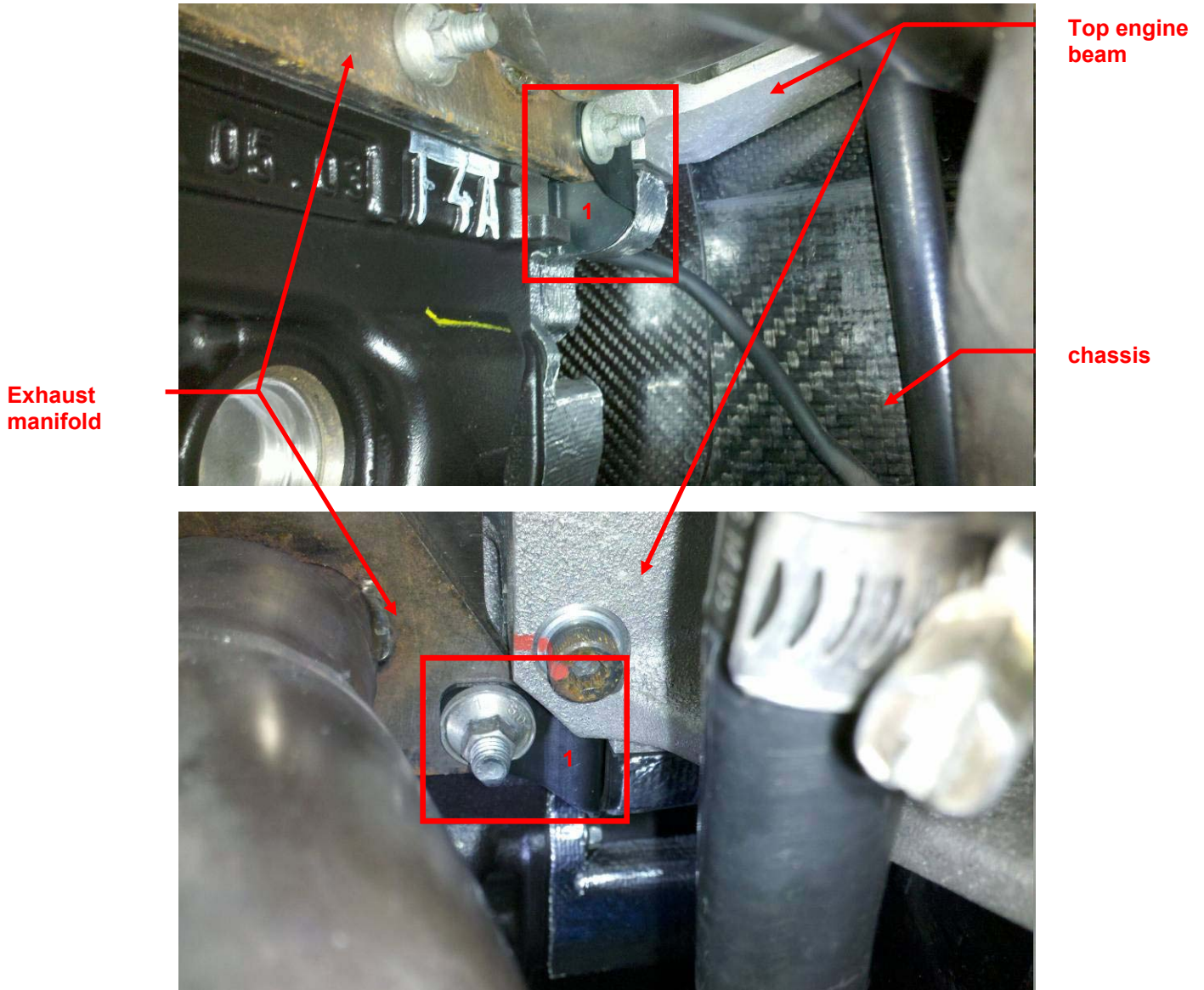

6. Gearbox primary shaft cap

Renault Sport recommends you to check if the cap of the primary shaft is not moving or exceeding the shaft end.

If the cap is moving, you must check if the casing is not worn before to replace it. New caps with a slightly bigger diameter (ref. 01 01 910 105) are now available separately from your Renault Sport spare parts Department. The cap must be pressed and stuck using high retaining glue (like Loctite® 648).

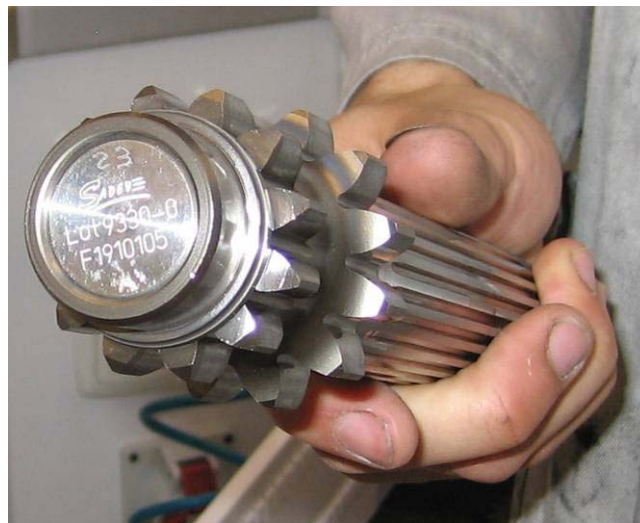

The cap must not exceed the primary shaft

Note: In case of a worn casing, please contact the Renault Sport Technical support.

7. Roll hoop cover

A mistake has been found in the trimming process of the roll hoop cover. The trim made on the top of the cover to pass the strap can be too small not to damage the roll hoop cover when the car is lifted:

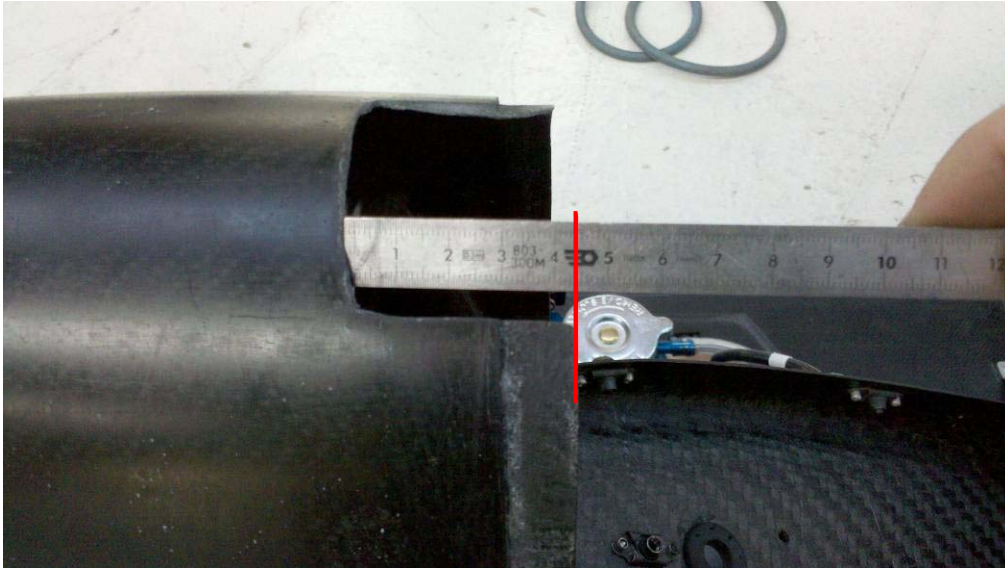

45mm is too short for the strap

For this reason, team must trim the wrong covers respecting the maximal quote of 55mm, measured as shown below:

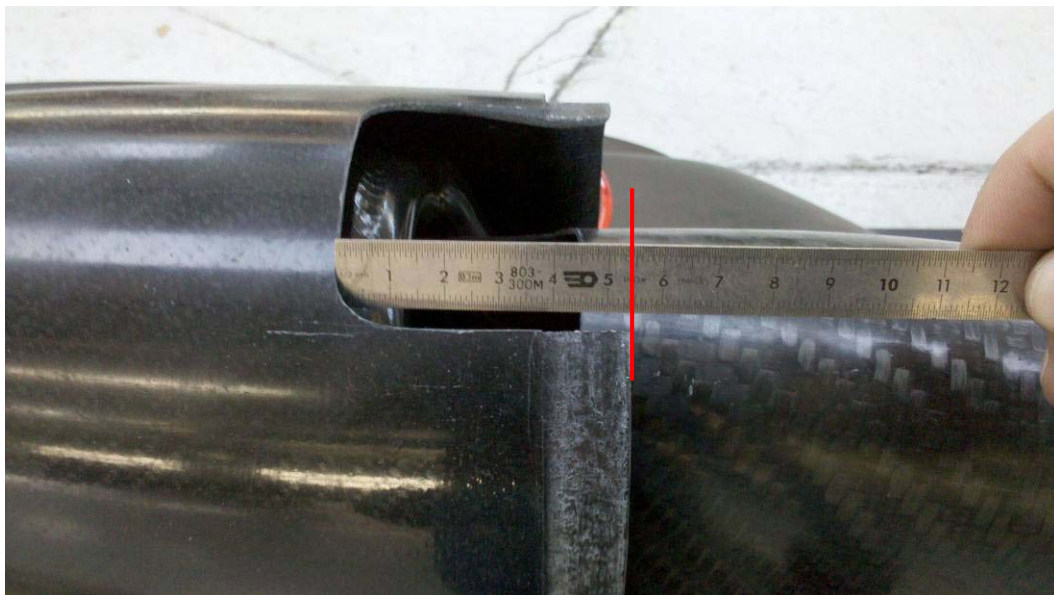

8. Differential ramps mounting

Renault Sport reminds you that there is only one ramp mounting allowed for the Formula Renault 2.0. The ramp must be fitted as shown below to respect that the ramp of 70° is used for acceleration and the ramp of 65° for braking.

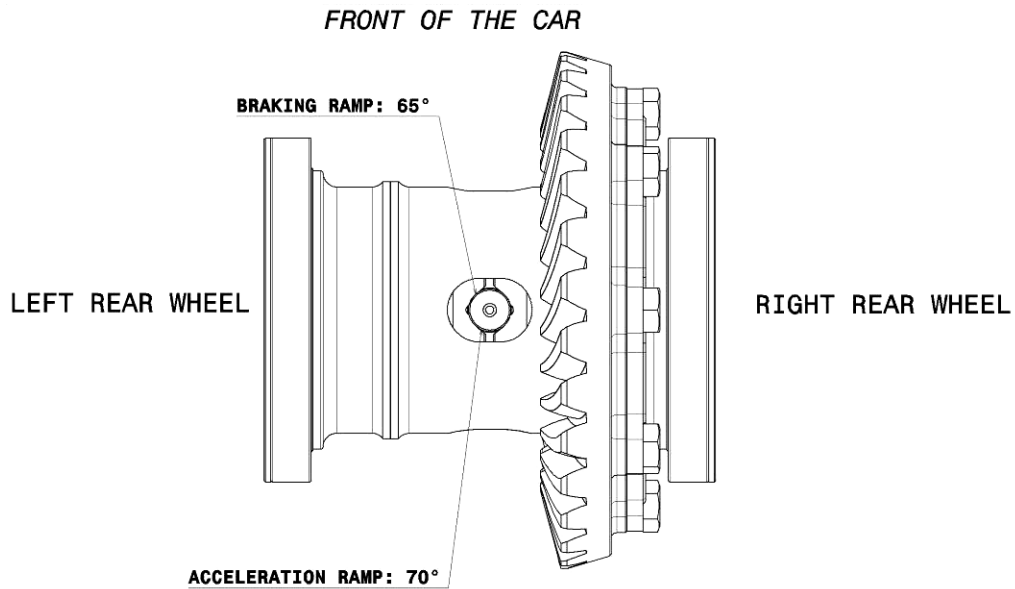

Good mounting