

REFERENCE	BT_2010_FR20_23_UK
DATE	30 th November 2010
SUBJECT	new catalytic design, reinforced rear Ackermann, GB command servicing, front flap mounting, Thermal shield for timing belt protection
PART	catalytic converter, rear Ackermann, actuator, powerbox, timing belt thermal shield

1. New catalytic converter internal design

The internal design of the catalytic converter has been improved to prevent the internal from moving down inside the tube.

The level of performance of this part is identical to the previous version.

Both old and new types are now allowed. Only the new type is now available from your Renault Sport spare parts dealer.



Old design



New design: 1 welded ring (1) + 4 welded pins added (2)

2. Rear Ackermann

The rear Ackermann has been reinforced. The new type is now the only one available and keeps the same references:

- LH: 77 11 166 234
- RH: 77 11 166 235



Note: both types will be allowed for 2011 season.

3. Actuator and powerbox service

Renault Sport strongly advises you to send your actuators and powerboxes to XAP Electronique in order to service them.

The complete service should cost between 200€ & 300€ excl. VAT & delivery. This price will include: actuator assembly & disassembly, replacement of seals, bearings (if necessary) & actuator supports, cleaning, and test.

You must send them to:

XAP electronique

Le Mercure - Bat A
1 740 Avenue du Maréchal Juin
30 900 Nîmes
FRANCE

To the attention of Stephane BUENDIA

Tél : +33 (0)4 66 02 94 94
Fax : +33 (0)4 66 02 94 90

Please don't forget to fill in a return form for each part.

During servicing, the actuator supports will be exchanged free of charge by reinforced ones on those which are not equipped. These supports have been upgraded following a few breakages this season, as shown below:

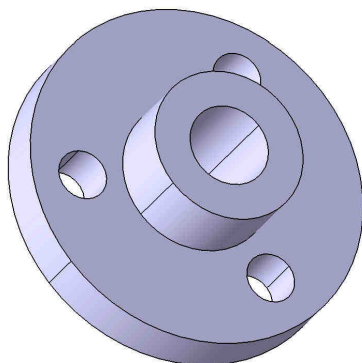
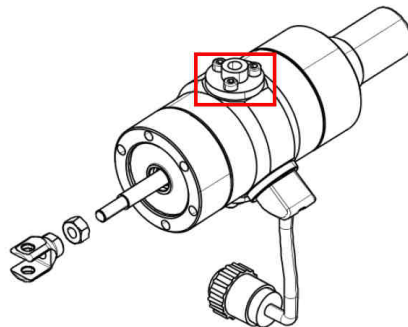

Original support

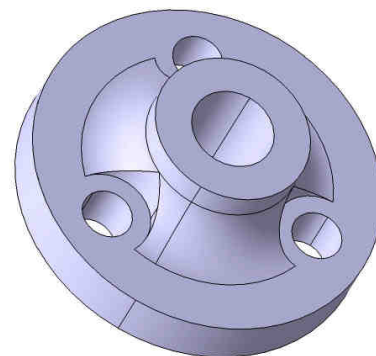

New support

The new part is also available from your Renault Sport spare part dealer under the reference 77 11 166 586.

Note: the main goal of this annual service is to get a real feedback on their use after a complete season. Renault Sport will be then able to recommend you a servicing frequency.

4. Front flap mounting

The front flap aluminium bracket is still breaking on a few cars. This bracket is breaking on the edge of the washer which is below the headscrew. For this reason, this washer has been replaced by a plastic cup washer, as shown below:



References:

- Plastic cup washer: 77 11 166 688
- M5 CSK screw: 77 11 154 887

Note: this washer is strongly recommended and will be in C category for 2011 season

5. Thermal shield for timing belt protection

The plastic protection of the timing belt may burn in some cases due to its proximity with the exhaust manifold. As a consequence, a thermal shield has been added to this protection as shown below:

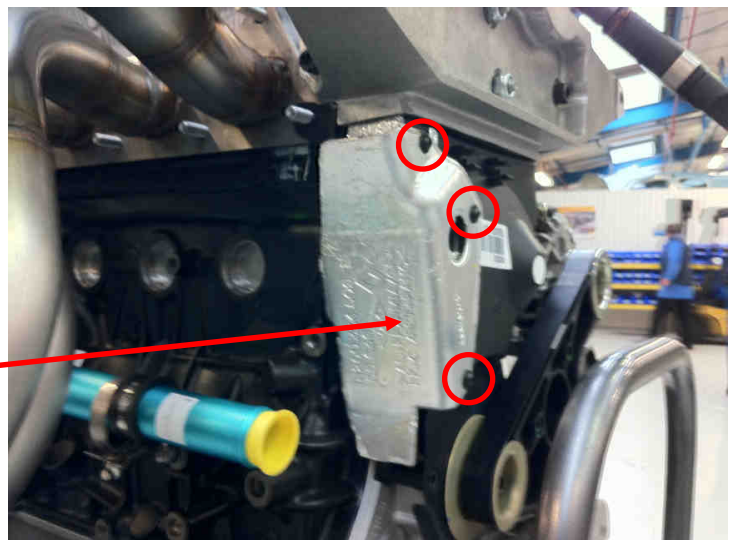

The reference of this new part is 77 11 166 687. You must note that 3 screws (ref: 77 03 016 553) are needed to mount it.

This part will be added to the engines during their next engine rebuild or engine dyno check for 2011 season. If the plastic protection is damaged, it will be also replaced. You won't be charged for them.

Note: this thermal shield will be mandatory for 2011 season. The screws will be in category C.