

REFERENCE	BT_2011_FR20_11_UK
DATE	16th May, 2011
SUBJECT	Throttle body mounting, pushrod strain gauges, fuel filter mounting, rear upright pin deployment
PART	Throttle body rubber, pushrod, rear upright pin, fuel filter assembly

1. Throttle body mounting

DEPLOYMENT: EURO CUP: 3rd meeting in Nurburgring

NEC: 4th meeting in Assen

UK: 4th meeting in Oulton Park

ALPS: 3rd meeting in Pau

The throttle body mounting has been improved. The rubber spacer ref. 77 11 166 059 will be replaced for free by a specific and softer one, ref. 77 11 166 712 to better damper the throttle body.

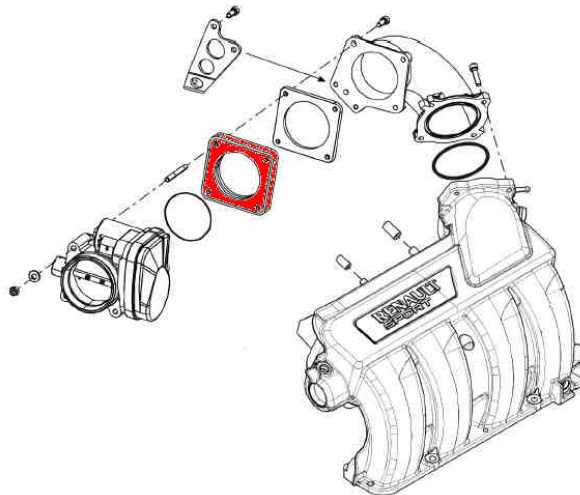

Once the new rubber spacer has been deployed, the old one will not be allowed anymore.

Note1: For those who have a spare engine, the rubber spacer will be also replaced but in a second time. Ask your Renault Sport spare parts dealer.

Note2: the original rubber spacer is not available anymore.

2. Pushrod strain gauges

Following Information Note n°3, Renault Sport chose to allow you to add strain gauges directly on pushrods. These gauges are allowed during races and qualifying.

For those who have already strain gauges ref. 77 11 166 401, Renault Sport will pay for the pushrod wirings, only if the operation is done by our Partner **Texys International**.

TEXYS INTERNATIONAL
ZA des Chamonds
Rue Edouard Branly
58460 Varennes-Vauzelles
FRANCE
Tel: +33 (0)386 212 718
Fax: +33 (0)386 212 449
@: p.leuwers@texense.com

In order to have access to this special offer, you must send back to Texys with your order, your old gauges with a copy of the Renault Sport purchase invoice. **Without this document, NO gauges will be taken in charge by Renault Sport.**

Texys informs you that there is a 5 days delay to wire 4 pushrods and 8 days for 8 pushrods.

Note: the gauges 77 11 166 401 won't be allowed anymore from 1st June, 2011.

3. New fuel filter mounting

It appears that the Schnorr washer (8) cannot always be used with the new fuel filter (ref. 77 11 161 845) as this filter is slightly shorter than the genuine one. Therefore, this washer can be removed only to ensure a good tightening of the new fuel filter ref. 77 11 161 845.

Renault Sport strongly advises to mount the washer when it is possible.

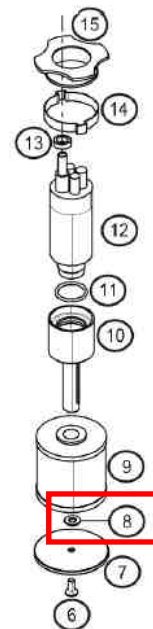



RENAULT SPORT

**FORMULA
RENAULT 2.0**

4. New rear upright pin deployment

The new rear upright pins (see Technical Bulletin n.9) will be slowly issued to every championship.

During the next national races (Nurburgring, Pau, Oulton Park, Assen, RedBull Ring), the new pins will be only provided to teams that need one due to a broken pin. 2 pins per car maximum will be provided for free

References:

- Pin: 77 11 166 718
- Nut: 77 11 166 719
- Grub screw: 77 11 166 714

Each team will have received 2 pins per car before middle of June. Therefore, this new pin will be the only one allowed from 4th July, 2011.

